

# INTRODUCTION TO B757/B767 MXP 400/800 SERIES STOWAGE BOX BROKEN PTT BUTTON

—  
05/04/2022

## Background

- Recently, B757/B767 operators had complained on the MXP storage boxes that had malfunction on the press to test button
- Typical part numbers: MXP806-1 (B767), MXP147 (B767), MXP891-3 (B757), MXP891 (B757)
- Press to test (PTT) button found to be failed during flight check performed by pilots/maintenance crew
- Prevalent complains are ***“TEST BUTTON BROKEN, BROKEN TEST LEVER, BROKEN SWITCHES, CRACKED TEST TAB”***

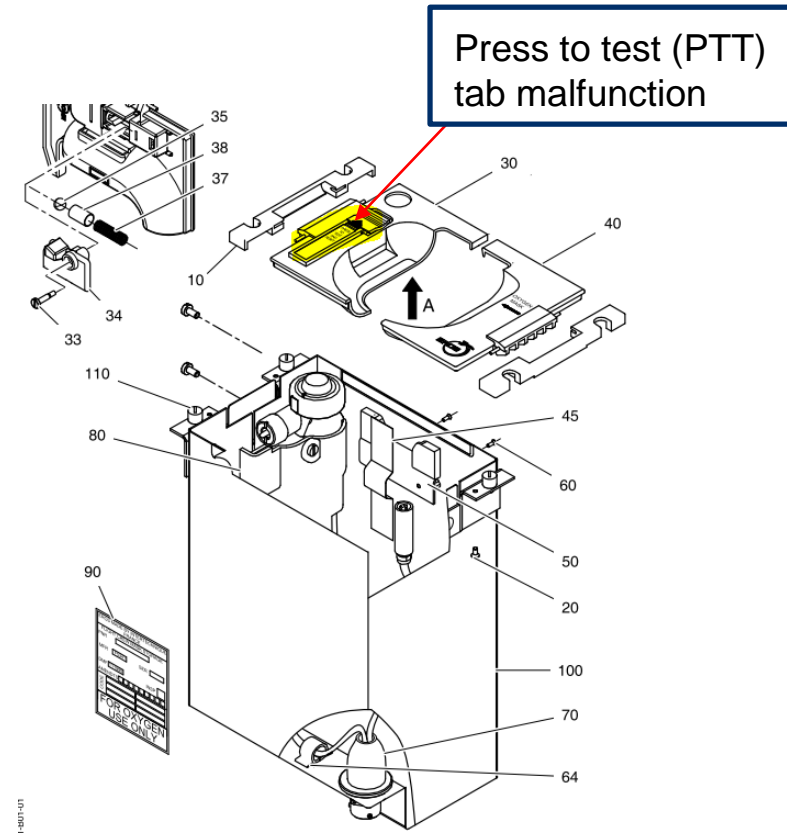

## Important information needed from operators

### ■ Stowage box data

- > Part Number
- > Serial Number
- > Date of Manufacture

### ■ Detailed description of how the box was being used at the time of incident

### ■ Photos of damage

### ■ What cleaning agents are these boxes are exposed and how often?

### ■ If there any special disinfectant implemented since COVID? What is used and how often?

### ■ Check with flight crew on feedback from crew about problems faced with MXP boxes